

© International Baccalaureate Organization 2021

All rights reserved. No part of this product may be reproduced in any form or by any electronic or mechanical means, including information storage and retrieval systems, without the prior written permission from the IB. Additionally, the license tied with this product prohibits use of any selected files or extracts from this product. Use by third parties, including but not limited to publishers, private teachers, tutoring or study services, preparatory schools, vendors operating curriculum mapping services or teacher resource digital platforms and app developers, whether fee-covered or not, is prohibited and is a criminal offense.

More information on how to request written permission in the form of a license can be obtained from <https://ibo.org/become-an-ib-school/ib-publishing/licensing/applying-for-a-license/>.

© Organisation du Baccalauréat International 2021

Tous droits réservés. Aucune partie de ce produit ne peut être reproduite sous quelque forme ni par quelque moyen que ce soit, électronique ou mécanique, y compris des systèmes de stockage et de récupération d'informations, sans l'autorisation écrite préalable de l'IB. De plus, la licence associée à ce produit interdit toute utilisation de tout fichier ou extrait sélectionné dans ce produit. L'utilisation par des tiers, y compris, sans toutefois s'y limiter, des éditeurs, des professeurs particuliers, des services de tutorat ou d'aide aux études, des établissements de préparation à l'enseignement supérieur, des fournisseurs de services de planification des programmes d'études, des gestionnaires de plateformes pédagogiques en ligne, et des développeurs d'applications, moyennant paiement ou non, est interdite et constitue une infraction pénale.

Pour plus d'informations sur la procédure à suivre pour obtenir une autorisation écrite sous la forme d'une licence, rendez-vous à l'adresse <https://ibo.org/become-an-ib-school/ib-publishing/licensing/applying-for-a-license/>.

© Organización del Bachillerato Internacional, 2021

Todos los derechos reservados. No se podrá reproducir ninguna parte de este producto de ninguna forma ni por ningún medio electrónico o mecánico, incluidos los sistemas de almacenamiento y recuperación de información, sin la previa autorización por escrito del IB. Además, la licencia vinculada a este producto prohíbe el uso de todo archivo o fragmento seleccionado de este producto. El uso por parte de terceros —lo que incluye, a título enunciativo, editoriales, profesores particulares, servicios de apoyo académico o ayuda para el estudio, colegios preparatorios, desarrolladores de aplicaciones y entidades que presten servicios de planificación curricular u ofrezcan recursos para docentes mediante plataformas digitales—, ya sea incluido en tasas o no, está prohibido y constituye un delito.

En este enlace encontrará más información sobre cómo solicitar una autorización por escrito en forma de licencia: <https://ibo.org/become-an-ib-school/ib-publishing/licensing/applying-for-a-license/>.

Mathematics: analysis and approaches
Higher level
Paper 3

Tuesday 11 May 2021 (morning)

1 hour

Instructions to candidates

- Do not open this examination paper until instructed to do so.
- A graphic display calculator is required for this paper.
- Answer all the questions in the answer booklet provided.
- Unless otherwise stated in the question, all numerical answers should be given exactly or correct to three significant figures.
- A clean copy of the **mathematics: analysis and approaches formula booklet** is required for this paper.
- The maximum mark for this examination paper is **[55 marks]**.

Answer **all** questions in the answer booklet provided. Please start each question on a new page. Full marks are not necessarily awarded for a correct answer with no working. Answers must be supported by working and/or explanations. Solutions found from a graphic display calculator should be supported by suitable working. For example, if graphs are used to find a solution, you should sketch these as part of your answer. Where an answer is incorrect, some marks may be given for a correct method, provided this is shown by written working. You are therefore advised to show all working.

1. [Maximum mark: 27]

This question asks you to explore the behaviour and key features of cubic polynomials of the form $x^3 - 3cx + d$.

Consider the function $f(x) = x^3 - 3cx + 2$ for $x \in \mathbb{R}$ and where c is a parameter, $c \in \mathbb{R}$.

The graphs of $y = f(x)$ for $c = -1$ and $c = 0$ are shown in the following diagrams.

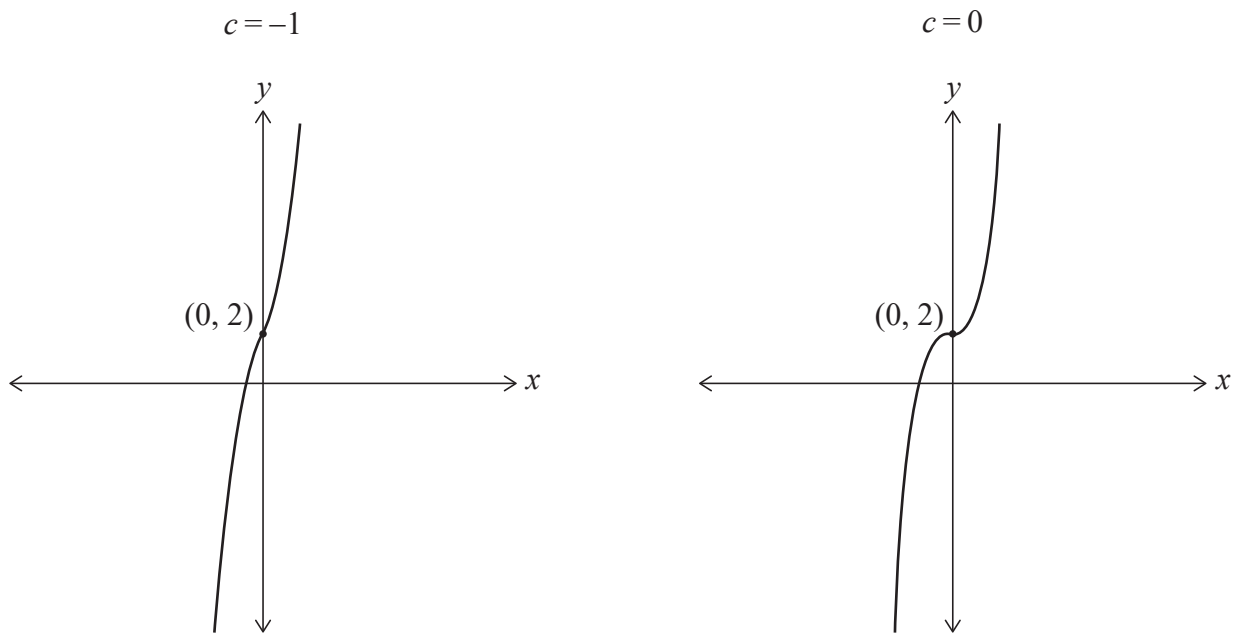

(a) On separate axes, sketch the graph of $y = f(x)$ showing the value of the y -intercept and the coordinates of any points with zero gradient, for

(i) $c = 1$; [3]

(ii) $c = 2$. [3]

(b) Write down an expression for $f'(x)$. [1]

(This question continues on the following page)

(Question 1 continued)

- (c) Hence, or otherwise, find the set of values of c such that the graph of $y = f(x)$ has
- (i) a point of inflexion with zero gradient; [1]
 - (ii) one local maximum point and one local minimum point; [2]
 - (iii) no points where the gradient is equal to zero. [1]
- (d) Given that the graph of $y = f(x)$ has one local maximum point and one local minimum point, show that
- (i) the y -coordinate of the local maximum point is $2c^{\frac{3}{2}} + 2$; [3]
 - (ii) the y -coordinate of the local minimum point is $-2c^{\frac{3}{2}} + 2$. [1]
- (e) Hence, for $c > 0$, find the set of values of c such that the graph of $y = f(x)$ has
- (i) exactly one x -axis intercept; [2]
 - (ii) exactly two x -axis intercepts; [2]
 - (iii) exactly three x -axis intercepts. [2]

Consider the function $g(x) = x^3 - 3cx + d$ for $x \in \mathbb{R}$ and where $c, d \in \mathbb{R}$.

- (f) Find all conditions on c and d such that the graph of $y = g(x)$ has exactly one x -axis intercept, explaining your reasoning. [6]

2. [Maximum mark: 28]

This question asks you to examine various polygons for which the numerical value of the area is the same as the numerical value of the perimeter. For example, a 3 by 6 rectangle has an area of 18 and a perimeter of 18.

For each polygon in this question, let the numerical value of its area be A and let the numerical value of its perimeter be P .

(a) Find the side length, s , where $s > 0$, of a square such that $A = P$. [3]

An n -sided regular polygon can be divided into n congruent isosceles triangles. Let x be the length of each of the two equal sides of one such isosceles triangle and let y be the length of the third side. The included angle between the two equal sides has magnitude $\frac{2\pi}{n}$.

Part of such an n -sided regular polygon is shown in the following diagram.

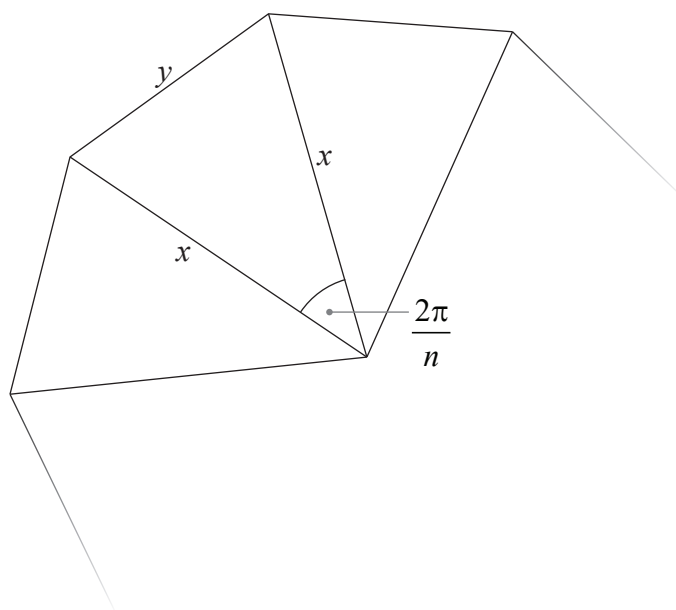

(b) Write down, in terms of x and n , an expression for the area, A_T , of one of these isosceles triangles. [1]

(c) Show that $y = 2x \sin \frac{\pi}{n}$. [2]

Consider a n -sided regular polygon such that $A = P$.

(d) Use the results from parts (b) and (c) to show that $A = P = 4n \tan \frac{\pi}{n}$. [7]

(This question continues on the following page)

(Question 2 continued)

The Maclaurin series for $\tan x$ is $x + \frac{x^3}{3} + \frac{2x^5}{15} + \dots$

- (e) (i) Use the Maclaurin series for $\tan x$ to find $\lim_{n \rightarrow \infty} \left(4n \tan \frac{\pi}{n} \right)$. [3]
- (ii) Interpret your answer to part (e)(i) geometrically. [1]

Consider a right-angled triangle with side lengths a , b and $\sqrt{a^2 + b^2}$, where $a \geq b$, such that $A = P$.

- (f) Show that $a = \frac{8}{b-4} + 4$. [7]
- (g) (i) By using the result of part (f) or otherwise, determine the three side lengths of the only two right-angled triangles for which $a, b, A, P \in \mathbb{Z}$. [3]
- (ii) Determine the area and perimeter of these two right-angled triangles. [1]
-

References: